



AEROSPACE INDUSTRY EXHIBITION TOKYO 2011

Date: Oct. 26th (Wed.) – 28th (Fri.), 2011

Location: TOKYO BIG SIGHT

How to apply for research institute zone

“Research Institute Zone” will be placed at the hall of ASET2011 for research institutes for aerospace-related technology.

You will exhibit in this zone in order to make occasion of “Announcement for research achievements” or “Relationship-building with enterprises”.

Please take advantage of this zone. We offer a special price.

1

Who Exhibit?

Research institutes for Aerospace-related technology of universities or technical colleges etc.

*Research Institute Zone is utilized only for announcement of Research Achievements.

*Research Institute Zone isn't utilized for publication or advertising activities as follows.

- To insert the name of associated enterprises on company name plate or guidebook.
- Advertising activities for instance recruitment for students.

2

Packaged Booth Price

	Booths	m ²	Exhibition booth fee
Type-A	1	4	Charge-free
Type-B	2	8	¥105,000 (tax included)
Type-C	4	16	¥262,500 (tax included)

*For details , please look at the reverse side.

3

Presentation

- ① Time: 60 minutes
- ② Fee: ¥31,500 (tax included)
- ③ Equipment: Projector, Screen, Stage, Microphone, Laser pointer

*You can't apply only for presentation

Booth Image

Type-A

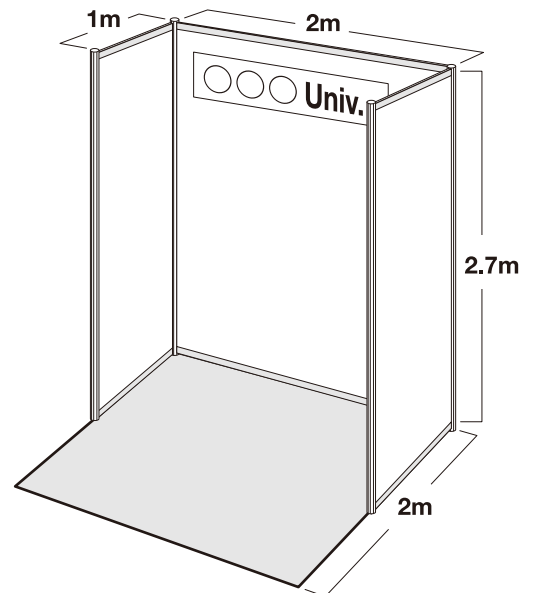

Contact

Tokyo Big Sight Inc.

AEROSPACE INDUSTRY EXHIBITION TOKYO 2011 Management office

3-11-1, Ariake, Koto-ku, Tokyo 135-0063, Japan

TEL +81-3-5530-1324 FAX +81-3-5530-1222

E-mail aset@tokyo-bigsight.co.jp

<http://www.tokyoaerospace.com/en>

[Packaged Booth Guide of "Research Institute zone"]

(1) Type-A (1 Booth)

Exhibition area	4 m ²	
Exhibition booth fee	Charge-free	
Equipment	<ul style="list-style-type: none"> • Booth partition 2m (back) × 1m (side) • Company name plate • Main power supply charge (500W) 	

(2) Type-B (2 Booths)

Exhibition area	8 m ²	
Exhibition booth fee	¥105,000 (tax included)	
Equipment	<ul style="list-style-type: none"> • Booth partition 4m (back) × 1m (side) • Company name plate • Main power supply charge (500W) • Table × 1 • Chair × 2 • Business card holder × 1 	

(3) Type-C (3 Booths)

Exhibition area	16 m ²	
Exhibition booth fee	¥262,500 (tax included)	
Equipment	<ul style="list-style-type: none"> • Booth partition 4m (back) × 1m (side) • Company name plate • Main power supply charge (500W) • Octanorm display box × 1 • Table × 1 • Chair × 2 • Reception desk × 1 • Brochure rack × 1 • Business card holder × 1 	

* If you need more than 4 booths, you have to apply 2 booths unit (¥157,500 / 2 booths).

* We provide other equipments in charge.

* Booth partition can be adjusted according to the place of booth.

* Please note that we might not accept your application in case of the number of application exceeds.

AEROSPACE INDUSTRY EXHIBITION TOKYO 2011

Application Form to Research Institute Zone

[Send to] Tokyo Big Sight Inc. AEROSPACE INDUSTRY EXHIBITION TOKYO 2011 Management office
3-11-1, Ariake, Koto-ku, Tokyo 135-0063, Japan Tel:+81-3-5530-1324 Fax:+81-3-5530-1222

This application must comply with rules and regulations on exhibit, shown on the back of this Application Form, as well as any other additional rules and regulations which the Organizers deem as necessary.

Date	20	/	/
-------------	-----------	---	---

◆ Applicant

Institute Name			
URL	http://		
Responsible Person	Name:	Title/Division	
Contact Person	Name:	Title/Division	
Address			
TEL		FAX	
E-mail			

◆ Booth and Presentation Required

Booth Type Required	<input type="checkbox"/> Type-A (1 booth: 4 m ²)	<input type="checkbox"/> Type-B (2 booths: 8 m ²)	<input type="checkbox"/> Type-C (4 booths: 16 m ²)
	¥0	¥105,000	¥262,500

*If you wish more than 4 booths, you have to apply 2 booths unit (¥157,500 / 2 booths).

Additional Booth Required	Additional Booth Fee (one set of two booths)	Number of Set Required	Total
	¥157,500	set	¥
Exhibitor's Presentation Required	Presentation Fee	Number of Presentation Required	Total
	¥31,500	session	¥

◆ Exhibit Detailed Contents

◆ Remarks

We are going to send confirmation of application. Please contact us if you don't receive it within a month of application. The personal information you provide to us will be rigorously managed at our company.

Management Office Use Only	No.	Date	Confirmed	Note
-----------------------------------	-----	------	-----------	------

Exhibition Rules and Regulations

Article 1. Organizers

1. The Tokyo Metropolitan Government and Tokyo Big Sight Inc. (hereinafter referred to as "the Organizers") will host the Aerospace Industry Exhibition Tokyo 2011 (hereinafter referred to as "the Exhibition").
2. The Organizers shall have all the authorities and responsibilities pertaining to the holding of the Exhibition.

Article 2. Exhibitors

The exhibitors shall be institutions, corporations and organizations that applied for participation in the Exhibition, and whose participation was approved by the Organizers.

Article 3. Secretariat

1. To implement the Exhibition, the Organizers shall set up the Aerospace Industry Exhibition Tokyo 2011 Secretariat (hereinafter referred to as "the Secretariat") in Tokyo Big Sight Inc.
2. The Organizers shall delegate the authority for operations related to the holding of the Exhibition to the Secretariat.

Article 4. Application for display in the Exhibition and approval

1. Those applying for participation in the Exhibition must first agree to comply with these Exhibition Rules and Regulations, fill in the necessary items in the Display Application Form (type in the necessary items in the case of an on-line application), and submit it to the Secretariat.
2. With the acceptance by the Secretariat of an applicant's application for participation in the Exhibition, the application for participation in the Exhibition shall be regarded to have been established between the Organizers and the display applicant.
3. The Organizers will check the content of the application and send an Application Confirmation Slip to those applicants that they are judged to be in compliance with the intent of the Exhibition by Organizers.
4. A contract between the Organizers and the applicant shall be regarded to have been established at the time that the Application Confirmation Slip in the preceding paragraph is sent.
5. Even after the contract has been established, the Organizers may reject an application for participation in the Exhibition if it judges that the content of the display fails to meet the objective of the Exhibition. The Organizers and the Secretariat shall not be held responsible for any losses, etc. that result from such rejection.

Article 5. Charging of the fees for display booths and payment thereof

1. After the contract between the Organizers and the applicant has been established, the Secretariat shall charge the fees for display booths to the Exhibitor.
2. The Exhibitor must pay the fees to the bank account designated by the Secretariat before Thursday, June 30, 2011. The Exhibitor must pay the bank transfer fees.

Article 6. Cancellation and/or changes in the display(s) by the exhibitor

1. If an exhibitor decides to cancel all or part of the displays after having applied for participation in the Exhibition, it may do so after clearly writing the fact and the reason(s) thereof, and notifying the fact to the Organizers.
2. The Exhibitor must pay the following cancellation fee to the Organizers, with the date on which the Organizers had received the aforementioned written document, made as the date of cancellation.

Date on which the Secretariat has received a notice of display cancellation in writing	Cancellation fee
After Wednesday, June 1, 2011 Before Thursday, June 30, 2011	50% of Exhibition Booth Fee
After Friday, July 1, 2011	100% of Exhibition Booth Fee

3. If an Exhibitor has not paid an amount corresponding to the above clause, it must pay it at once. If the amount which the Exhibitor has already paid exceeds the amount corresponding to the above clause, the Organizers shall return the surplus amount.
4. If an Exhibitor decides to change the form of display, it can do so only if it made an application for change to the Secretariat at least 90 days before the holding of the Exhibition and if the Organizers have approved of it.

Article 7. Cancellation of display by the Organizers

1. If the Organizers determine that the Exhibitor is not suited for the Exhibition, it can cancel the display at any time with the condition that it will return the display booth fee that has already been paid.
2. The Organizers may cancel the display of an Exhibitor who has failed to pay the exhibition booth fee by the designated date.
3. Exhibitors whose display has been cancelled based on the preceding paragraph shall pay 50% of the exhibition booth fee to the Organizers as a penalty for breach of contract.

Article 8. Determination and reallocation of the position of the exhibit booth

1. The Secretariat shall decide the position of the display booths by taking into consideration factors such as zoning, display field, displayed products, and the scale of the display.
2. The Secretariat may reallocate a booth even after the position of the booth has been announced, by taking into consideration factors such as enhancement of display effects and circumstances related to keeping the visitors in order. In this case, the Exhibitor cannot demand compensation for damage related to changes in the position of the booth and expenses that accrue in association with those changes.

Article 9. Prohibition of booth subleasing, etc.

The Exhibitor may not sublease, buy/sell, exchange, or transfer its company's booths without the Organizers' approval.

Article 10. Installation and removal of display items, etc.

1. The Exhibitor shall bring the display items, etc., to the venue and install them within the time frame that will be announced by the Secretariat at a later date. If the Exhibitor does not occupy the booth within this designated time frame, the Organizers shall regard the contract as having been cancelled, and shall possess the right to use said booth in any method they deem appropriate. In this case, the Exhibitor shall pay to the Organizers the cancellation fee set forth in Article 6, with said designated date being established as the date of cancellation.
2. The Exhibitor must first obtain the approval of the Secretariat for bringing in, moving, and carrying out of the display items, etc., during the period of the Exhibition, and must proceed with the work only after having received the approval.
3. Displayed items and decorations, etc., placed inside the booth must be taken out within a time frame that will be notified by the Secretariat at a later date. Any items that are not taken out within this time frame shall be removed by the Organizers. Any costs that accrue as a result shall be borne by the Exhibitor, and charged to the Exhibitor by the Secretariat at a later date.

Article 11. Use of the booth

1. All demonstrations or any other advertising and sales activities shall be restricted to areas inside the company's booth. The Exhibitor shall be held responsible for ensuring that the passageways near the booth will not become congested because of its demonstrations or any other advertising and sales activities.
2. The Exhibitor must give sufficient consideration to making sure that the decorations and designs of its booth do not block the adjacent booths of other companies. If a complaint is lodged from an adjacent booth, the Secretariat shall determine the need for changing the decorations and/or designs from the standpoint of running and managing the Exhibition. If changes are judged to be necessary, the Exhibitor of said booth must agree to such changes.
3. The Secretariat shall have the right to restrict display items that are deemed problematic because of the sound they emit, the method of operation, materials, or any other reasons. It also has the right to prohibit or remove display items that do not match the objectives of the Exhibition, based on the standpoint of running and managing the Exhibition. This authority shall cover people, actions, printed matter and any other matters which the Organizers regard as being problematic.
4. In the aforementioned clause, if there is a need for restrictions or removal, the Organizers and Secretariat shall not be held responsible and the Exhibitor cannot make a claim against the Organizers or Secretariat for any expenses that accrue in conjunction with said restrictions or removal.

Article 12. Exemption from obligation to pay compensation

1. The Organizers and the Secretariat shall have no obligation, under any circumstances, to pay compensation for any form of physical harm, including theft, loss, damage, etc. to the display items, the articles brought into the venue in connection with the display (including personal belongings brought into the venue by the Exhibitor or people associated with the Exhibitor), or the display booth facilities, or to all of the above.
2. The Organizers and the Secretariat shall have no obligation, under any circumstances, to pay compensation for any physical harm or bodily harm to the Exhibitor, the Exhibitor's employees or agents, other people associated with the Exhibitor, or a third party, or to all of the above, that is caused by the display of the Exhibitor (including demonstrations, etc.), or the fact of the Exhibitor putting a display in the Exhibition, or by all of the above.

Article 13. Compensation for damages

The Exhibitor must pay compensation for any and all losses and damages resulting from breakage of the venue building structures or facilities, breakage of a third party's display booth facilities and displays, and/or injury to the human body caused by the carelessness of the Exhibitor or its agents.

Article 14. Cancellation of the Exhibition

1. If the Organizers judge that the holding or continuation of the Exhibition is impossible or difficult due to reasons attributable to an act of God, it can cancel or suspend the holding of the Exhibition.
2. Reasons attributable to an act of God mentioned in the previous clause shall mean typhoons, floods, wind damage, epidemics, earthquakes, fires, explosions, other accidents, actions, violence, civil strife, strikes or other labor disputes caused by public enemies, as well as decisions on legal regulations made by the government and local public authorities.
3. The Exhibitor cannot claim compensation from the Organizers or the Secretariat for damages and losses it has suffered because of the latter's decisions.

Article 15. Compliance with the stipulations set forth in Japanese laws and regulations

The Exhibitor must comply with the stipulations set forth in the laws and regulations of Japan. It must pay special attention to the laws and regulations related to aviation and fire-fighting, and to the import/export of weapons.

Article 16. Compliance with the Exhibition Rules and Regulations

1. The Exhibitor must comply with these Exhibition Rules and Regulations as well as rules, etc., that the Organizers provide for separately (Display Application Form, Display Manual, etc.).
2. The Organizers can change various rules and regulations because of unavoidable reasons. The Exhibitor must agree to this in advance and comply with the new rules and regulations, etc., that will be established after such changes.
3. Should the Exhibitor violate these rules and regulations, etc., the Organizers may reject its exhibits, regardless of the reason. The Organizers and the Secretariat shall not be held responsible for any losses, etc., that accrue in such a case.
4. These Exhibition Rules and Regulations, as well as rules, etc., that the Organizers provide for separately and the related contracts shall be interpreted in accordance with the laws of Japan. The Tokyo District Court shall have exclusive jurisdiction over lawsuits and other procedures related to these rules, regulations and contracts.

Article 17. Questions and doubts

The Organizers shall retain the right to make the final decision regarding any matters not stipulated in the Exhibition Rules and Regulations, or if there are any questions and doubts regarding the Exhibition Rules and Regulations.